

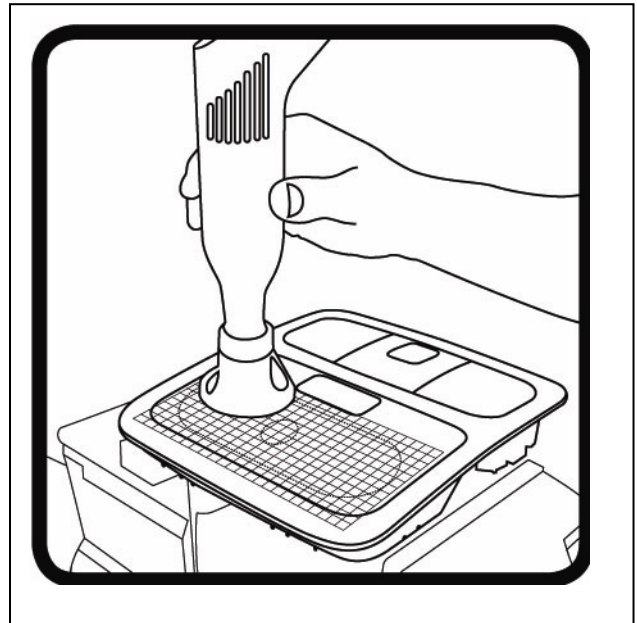

Speak Easy.

Connected.

Integrated.

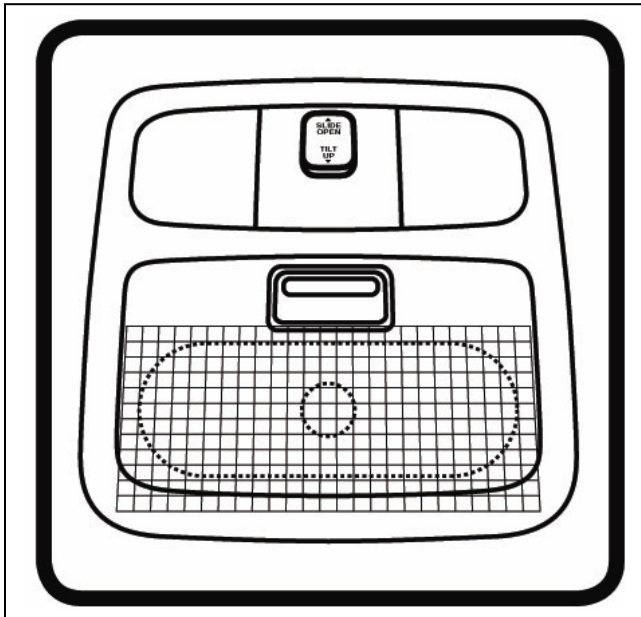

INSTALLATION INSTRUCTIONS

IMPORTANT – PLEASE READ

- **DO NOT ATTEMPT TO INSTALL THIS PRODUCT YOURSELF UNLESS YOU ARE A PROFESSIONAL MOBILE ELECTRONICS INSTALLER.** AutoIntelligence strongly recommends that BlueConnect® be installed in your vehicle by a professional mobile electronics installer or an approved BlueConnect® installer as described in the installation instructions section provided. Questions regarding installation should be directed to AutoIntelligence prior to installation.
- **DO NOT INSTALL THIS PRODUCT WITHOUT CONFIRMING PHONE COMPATABILITY WITH BLUECONNECT®.** Not all Bluetooth® phones are compatible with BlueConnect®. There are a variety of Bluetooth® cell phones available today with different Bluetooth® “profiles”. Phones must support the Bluetooth® “hands-free profile” to be compatible with BlueConnect®. Because of the variety of Bluetooth® phones that exist and the emergence of new models every day, AutoIntelligence recommends that you check with your cell phone provider or go to www.jciblueconnect.com on phone compatibility before purchasing or installing this product.
- **DO NOT ATTEMPT TO INSTALL THIS PRODUCT IN THE VEHICLE WITHOUT CONFIRMING THAT THERE IS ADEQUATE SPACE FOR ALL BLUECONNECT® COMPONENTS.** BlueConnect® has specific installation requirements and will not fit all vehicle applications. Installation requires cutting a hole in either an overhead console or a molded headliner. Do not attempt to have BlueConnect® installed in your vehicle without first confirming that it will accept the installation of this product as outlined in the vehicle application section. This product should not be installed on any vehicle that does not meet these requirements. Vehicles with limited overhead space, such as in convertibles or vehicles with sunroofs, may not accept installation of BlueConnect®.
- **DO NOT CUT OR ALTER THIS PRODUCT’S WIRING.** The BlueConnect® wiring harness has been specially designed to meet most installation requirements. Cutting or altering the wiring in any way could cause damage to the unit and adversely effect it’s performance.

WARNINGS

1. DO NOT operate any function that takes your attention away from safely driving your vehicle. Any function that requires your prolonged attention should only be performed after coming to a complete stop. Always stop the vehicle in a safe location before performing these functions; failure to do so may result in an accident.
2. Minimize viewing User Interface Board while driving. Viewing the User Interface Board may distract the driver from looking ahead of the vehicle and cause an accident.
3. DO NOT disassemble or alter the product in any way; doing so may result in an accident, fire or electric shock.
4. Use only in vehicles with a 12-volt negative ground. Check with your dealer or AutoIntelligence if you are not sure. Failure to do so may result in fire.
5. Use the correct ampere rating when replacing fuses. Failure to do so may result in fire or electric shock.
6. DO NOT block vents or radiator panels. Doing so may cause heat to build up inside and may result in fire.
7. DO NOT place hands, fingers or foreign objects in insertion slots or gaps. Doing so may result in personal injury or damage to the product.

IF A PROBLEM APPEARS

Halt use immediately if a problem occurs. Failure to do so may cause personal injury or damage to the product. Return it to your authorized AutoIntelligence dealer or the nearest AutoIntelligence service center for repairing.

IMPORTANT

TEMPERATURE – Be sure the temperature inside the vehicle is between +60 degrees C (+140 degrees F) and –10 degrees C (+14 degrees F) before using this product.

MOISTURE & CONDENSATION – The HFM (Hands Free Module) must be installed in an area free of any moisture and condensation.

MAINTENANCE – If you have problems, do not attempt to repair the unit or any of its parts yourself. Contact AutoIntelligence immediately at 800-406-7132 to report the problem.

BLUECONNECT® OPERATION

The BlueConnect® handsfree system is activated once the pairing process has been completed for each phone that is paired with the system. The pairing process is specific to each phone. Simply follow the pairing directions that are included with this product and those that are provided with the Bluetooth® cell phone manual. If you cannot locate the cell phone operator's manual, please consult www.jciblueconnect.com for pairing information.

To use BlueConnect® press and release the PHONE button one time, and follow the voice commands. Once you become familiar with the sequence of prompts and commands you can expedite the process by pressing and releasing the VR button and then giving a command.

Included



UIB - USER INTERFACE
Retainer & Assembly



CONTROL MODULE
HFM- Handsfree Module



WIRE HARNESS
Main Harness – UIB to
HFM with power leads



HARDWARE BAG
(3) T Taps
(3) Wire Ties
(3) Male Insulated Spades
(4) Foam Adhesive Pads
Connectors
(4) 3.5mmx 19mm screws
(3) Tie Straps
(1) Ground Terminal

ALSO INCLUDED:

- INSTALLATION INSTRUCTIONS
- ADHESIVE CUTTING TEMPLATE
- USER GUIDE
- PRODUCT REGISTRATION CARD

Tools Needed

Pencil
Pliers
Blade Screwdriver
Hand Held Rotary Tool
Rotary Cutting Bit

Plastic Tucking Tool
Phillips Screwdriver
T-15 Torx Screwdriver & Bit
Digital Voltage / OHM Multi-Meter
Rotary Sanding Drum

Modeling Knife
Knife Blades

INSTALLER

PLEASE READ PRIOR TO INSTALLATION

1. Have you verified that the customer's phone is compatible with BlueConnect®?
2. Have you determined which method of installation is best for the customer's vehicle? Installation into the overhead console is best if all parts fit as described in the installation section of this manual. If installation in an overhead console is not possible then determine if there is room in the headliner as described in the installation section of this manual. The headliner must be molded for this type of application
3. Have you verified that there is adequate space for the proper installation of all parts before cutting any holes or making any permanent alterations to the vehicle? First, there needs to be adequate room to install the UIB in an overhead console, sunglass bin, or headliner. Check the clearance on the "back side" before you commit to the installation. Check for sunroof motors, wiring harnesses, etc. Also check to ensure that there is a proper location to "hide" the HFM (Black Box) within the working range / length of the main harness. The HFM should fit between the headliner and the roof panel without making any noticeable bulge or visual indication of its location once the installation is completed.
4. Does the vehicle have an overhead console similar to the one shown in Figure A? If **YES**, then use the supplied template to determine if the overhead console will accept installation and fit of the UIB assembly. If **NO**, the vehicle does not have an overhead console or if the overhead console will not accept the UIB assembly, then read # 5 for possible installation of the UIB assembly in the headliner.

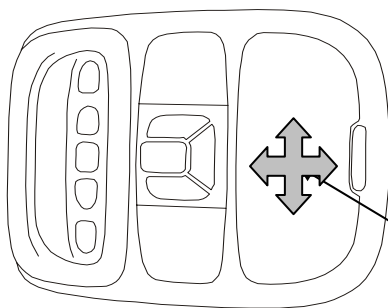

Fig A

NOTE: It is very important to determine if the selected location will accept the installation of the UIB assembly and the HFM before starting the installation.

UIB Assembly Location

5. Does the vehicle have available space in the molded headliner (upfront and above the driver or between the driver and passenger) to support the UIB assembly with a flush mounted installation? If **YES**, make certain that the location

- selected is within the working range / length of the main harness. If *NO*, then do not attempt to install this product.
6. Does the vehicle have a 12-14 volt electrical system? Do not attempt to install this product if it does not. Refer to the vehicle owner's manual to confirm the vehicle's voltage.
 7. What power source will you use? BlueConnect® requires a power, ground and ignition wire to operate properly. The wiring harness included has been designed to connect to either an overhead power source or to the fuse box via the A-pillar.
 8. If connecting BlueConnect® to the fuse box via the A-pillar, is the vehicle equipped with factory side curtain airbags? If *YES*, special caution should be taken when removing the A-Pillar cover. Before removing the A-Pillar cover, disconnect the negative battery terminal and wait 90 seconds.

The information in this manual has been carefully compiled through vehicle installation results, factory standards, test data, and is accurate to the best of our ability. We do not, however, warrant the accuracy of this information against changes in vehicle design or the use or misuse of this product or this information. It is the responsibility of the installer to inspect and verify that all wire attachments have been made properly prior to and after the installation of BlueConnect® to assure proper operation. AutoIntelligence will not accept any responsibility for damage to the vehicle or injury to its occupants caused by the misuse of this product or information, for improper installation of this product, or for the connection of this product to incorrect wires. Failure to comply with any of the installation instructions or warnings provided could cause the BlueConnect® system or the vehicle to malfunction, damage components, and / or cause personal injury to you and or your passengers.

- When installing this product use only digital voltage/ OHM multi-meter.
- Always use a plastic tucking or trim tool to remove plastic trim from vehicle to avoid causing damage.
- When removing the terminal connector do not pull on the wires. Pulling on the wires may cause damage and or intermittent power failure.
- When using wire tie end to secure the harness, clip the tag end after securing the harness into place.
- When securing T-taps, make sure the T-tap is the appropriate size for the gauge size of the selected wire.
- Disconnect the negative cable from the vehicle battery before starting any installation.

OVERHEAD CONSOLE INSTALLATION

- Refer to the questions on page 5 & 6 of this document before starting the installation process.
- ALWAYS disconnect the NEGATIVE (-) terminal at the battery before starting ANY electrical installation on ANY vehicle.

1.0 REMOVE THE OVERHEAD CONSOLE BOX

Not all overhead consoles can be removed in the same way. Refer to manufacturer's service manual if you have specific questions about the console's removal. Some consoles have clips and or hidden screws. Never use "excessive force" to remove any plastic parts and only use a plastic tucking tool to pry plastic parts.

Carefully remove all clips and / or screws as needed to drop the console down and store them in a secure location. Carefully lower the console and disconnect all terminal connections. After the console is removed set it aside where it can't be damaged.

2.0 PREPARE THE CONSOLE SURFACE

Determine the best location for UIB assembly in the overhead console. Preferred installation of the UIB is in a storage bin door, like a sunglass or storage bin door. It can also be installed in other console areas if space permits.

Once an area is selected, place the cutting template provided on the console surface area and review the area carefully, front and back, to confirm that the UIB will fit (on all sides) before the hole is cut. After confirming that the UIB will fit, center the template and locate the center point on the installation surface. Using a pencil, mark the center point position on the console surface.

Note: For this installation we have used the center point for horizontal positioning and the edge of the release button for vertical positioning.

Remove the self-adhesive backing from the template. Using the center point mark and the reference lines on the template, adhere the template to the console centering it both horizontally and vertically. Once adhered, check the outside perimeter of the oval line to make sure that it is centered and there is adequate space around it for the UIB faceplate to fit flush with the console surface. Reposition the template as needed.

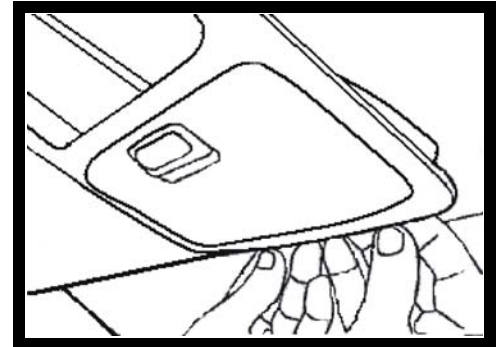

Step 1.1 – lower the overhead console box

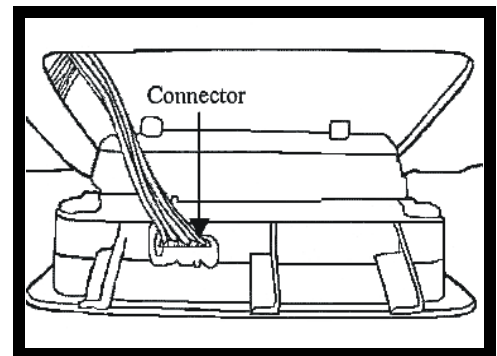

Step 1.2 - Disconnect all terminal connections

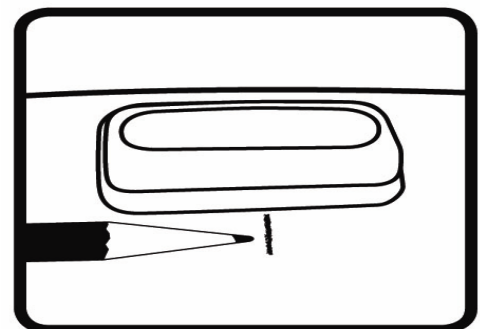

Step 2.1 - Locate the center point

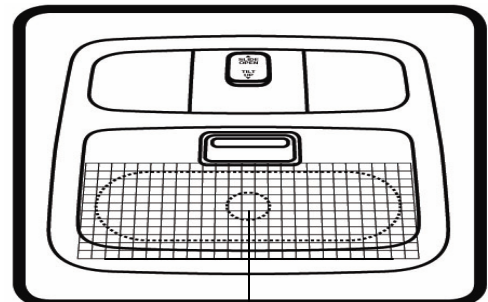

Step 2.2 – Center the template

3.0 CUTTING THE HOLE

Secure the overhead console for cutting. Be careful not to damage the console when securing it. Using a cutting tool, such as a hand held rotary tool, prepare to cut out the area described on the template (*the oval area*). **START CUTTING FROM WELL INSIDE OF THE LINE. DO NOT CUT OUTSIDE OF THE LINE.** Any additional trimming or cutting that is needed should be done from the inside of the line. Use a sanding drum to enlarge and smooth the opening as needed.

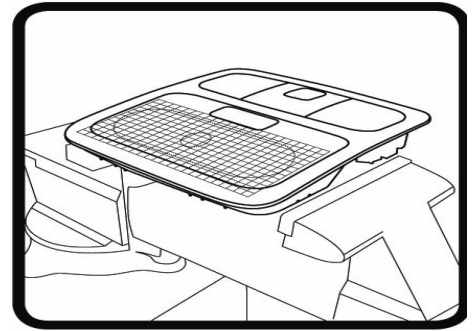

3.1 – Secure the overhead console firmly being careful not to damage it

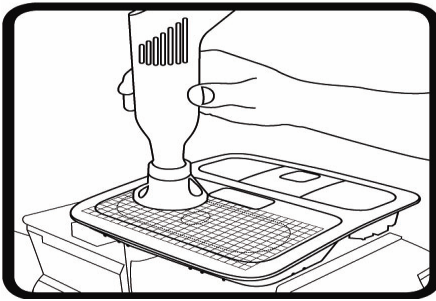

3.2 – Use a Hand Held Rotary Tool to carefully cut the area out for the UIB

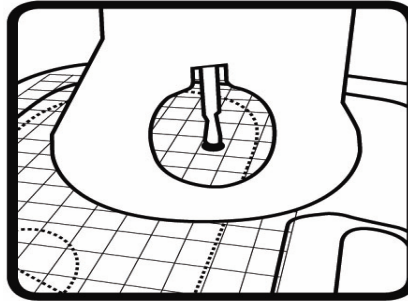

3.3 – Your initial cut should be well *inside of the line*

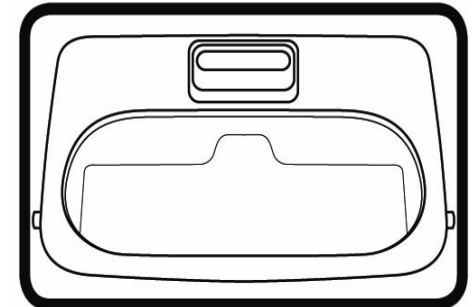

3.4 – Opening cut out and smoothed

4.0 CUT AN OPENING FOR THE WIRE HARNESS TO PASS THROUGH

The UIB assembly must be accessible from the backside for the main harness connector. It may be necessary to cut a 1” (25mm) hole in the backside of the overhead console or sunglasses compartment to allow connection of the harness to the UIB assembly.

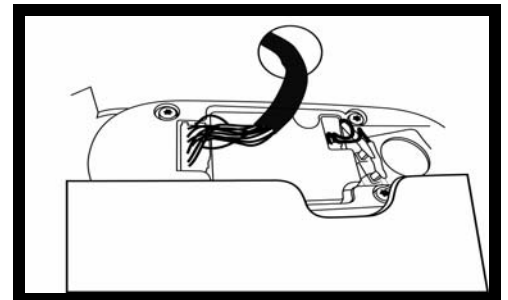

4.1 – Opening cut out of back for wiring to pass through

5.0 INSERTING THE UIB ASSEMBLY

Insert the UIB assembly through the opening of the overhead console from the front side. Note the position and orientation of the microphone and speaker. The microphone (smaller series of holes in the UIB faceplate) should always be closest to the driver in order for BlueConnect® to function properly. (This unit is intended for North American left hand drive vehicles only).

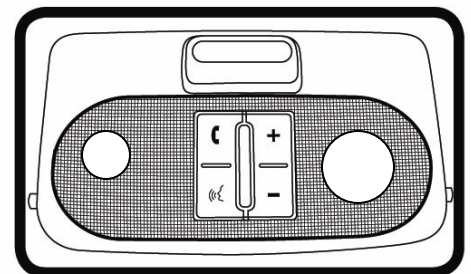

5.1 – Insert and position the UIB so the microphone (smaller series of holes) faces in the direction of the driver

6.0 ATTACHING THE UIB ASSEMBLY RETAINER

The UIB assembly retainer is designed to fit one way. It attaches to the back of the UIB assembly from the rear of the opening using the four screws supplied.

Do not substitute any other screws for assembling this unit. The length, diameter and thread type are specific for this application. The use of other screws may damage the housing or fail to properly secure the unit. Never use an electric drill or cordless screwdriver to assemble these components.

Insert the 4 screws by hand into the retainer screw holes. Make any final adjustments to the positioning of the UIB assembly. Hold the UIB assembly gently, yet securely, to the installation surface area and begin tightening the screws using a T-15 Torx bit. Tighten the screws ¼ turn at a time to eliminate any gaps where the cover screen contacts the surface or if the unit is loose. Do not over tighten when securing the unit.

IMPORTANT – PLEASE READ

There is no need to “crush” the material between the cover screen and the retainer.

Over tightening screws will cause distortion and discoloring of the cover screen.

Over tightening screws can also cause the operating buttons to malfunction.

If a screw is missing or lost, contact AutoIntelligence for a replacement.

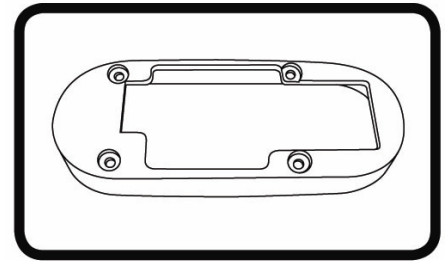
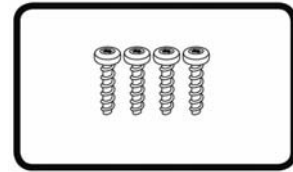

6.1 – UIB Retainer and screws. The retainer can only be installed in one direction.

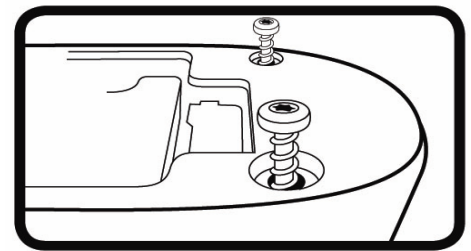

6.2 – Align the UIB retainer screws and tighten by hand only.

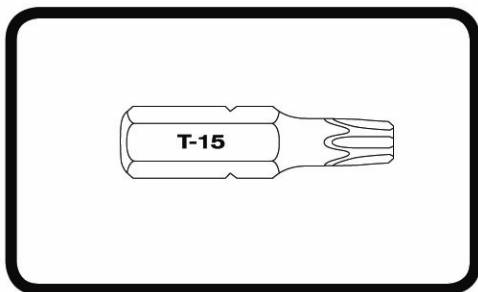

6.3 – Installation requires using a T-15 Torx bit.

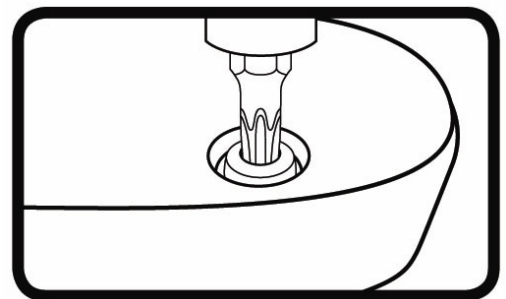

6.4 – Do not use an electric or cordless screwdriver. DO NOT over tighten.

7.0 INSPECTION OF THE UIB ASSEMBLY

Once the UIB assembly is attached and in place, check that it is snug all around its perimeter and secure. Check that each of the UIB buttons operates with a “crisp click” when depressed and recoils to the neutral position quickly and freely. The UIB assembly should be secured without gapping or distorting the cover screen. The microphone should be toward the driver.

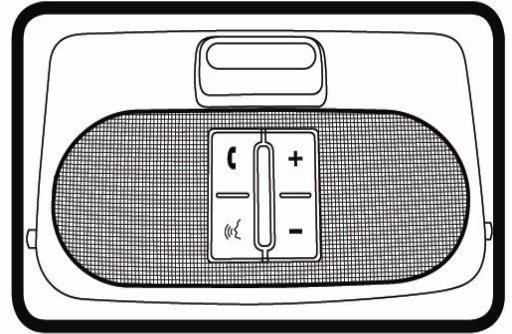

7.1 – The UIB should be secure without any gapping or distorting of the cover screen

8.0 CONNECT THE HARNESS TO A POWER SOURCE

BlueConnect® requires a power, ground, and ignition wire to operate properly. The wiring harness included has been designed to connect to either an overhead power source or to the fuse box via the A-pillar.

If the vehicle is equipped with side airbag curtains and you are connecting BlueConnect® to the fuse box via the A-pillar, special caution should be used when removing the A-Pillar cover. Before removing the A-Pillar cover, check that the negative battery terminal has been disconnected and you have waited 90 seconds before removal.

Using a digital voltage / OHM meter, locate a constant power source (BATT +), an accessory power (ACC +), and a ground wire (GND -).

Using a T-tap, connect the main harness black wire to vehicle’s ground wire (GND -).

Using a T-tap, connect the red wire to the vehicle’s constant power source (BATT +).

Using a T-tap, connect the yellow wire to the vehicle’s accessory power source (ACC+).

Note: Dome lamps or map lamps typically supply (BATT+) and (GND-). (ACC+) source maybe available in overhead harness or fuse box depending on vehicle.

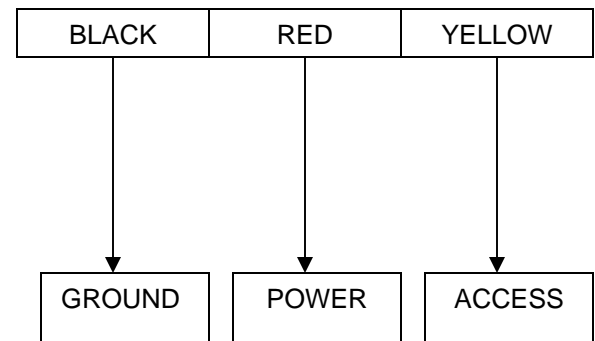

8.1 – Wiring Requirements

9.0 INSTALL THE HFM UNDER THE HEADLINER

Connect the main wire harness connector to the HFM control module. Place the HFM control module into the selected location. For this installation example we chose to locate the HFM between the headliner and the roof panel. Secure the HFM in place by using the supplied “two faced” adhesive foam tape or use another means to secure it and prevent movement and rattling.

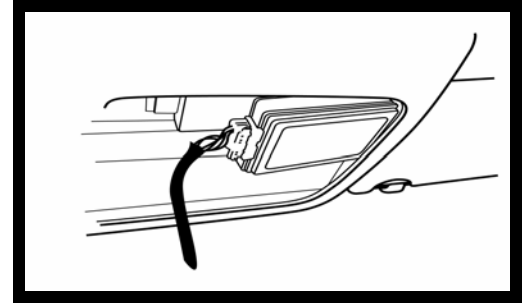

9.0 – Locate an area for the HFM above the headliner or in the console where it can be installed and out of the way

10.0 UIB ASSEMBLY TERMINAL CONNECTOR

Route the main wire harness to the installed UIB assembly location. Connect the main harness connector into the UIB assembly. Ensure that all of the connectors have been fully inserted. A “Click” is heard when a connector is inserted properly.

11.0 RE-INSTALL OVERHEAD CONSOLE

When applicable, reconnect the vehicle’s wiring harness to the overhead console. Re-install the overhead console to its original location making sure that all wires are properly routed and clear of any sharp edges.

12.0 FUNCTION CHECK

Turn the ignition key to the ACC position. The operating buttons on the BlueConnect® UIB faceplate will be illuminated. Allow 5 seconds for the system to self-check before pushing and releasing the Phone button. The Phone button will activate and de-activate the system.

The Blue L.E.D. on the circuit board will illuminate the center bar and an audible acknowledgement from the system will be heard.

BlueConnect® is now ready for the pairing process where it is programmed to communicate with a particular cellular phone. For instructions on the Phone Pairing process, please refer to the User Guide included in the box of contents.

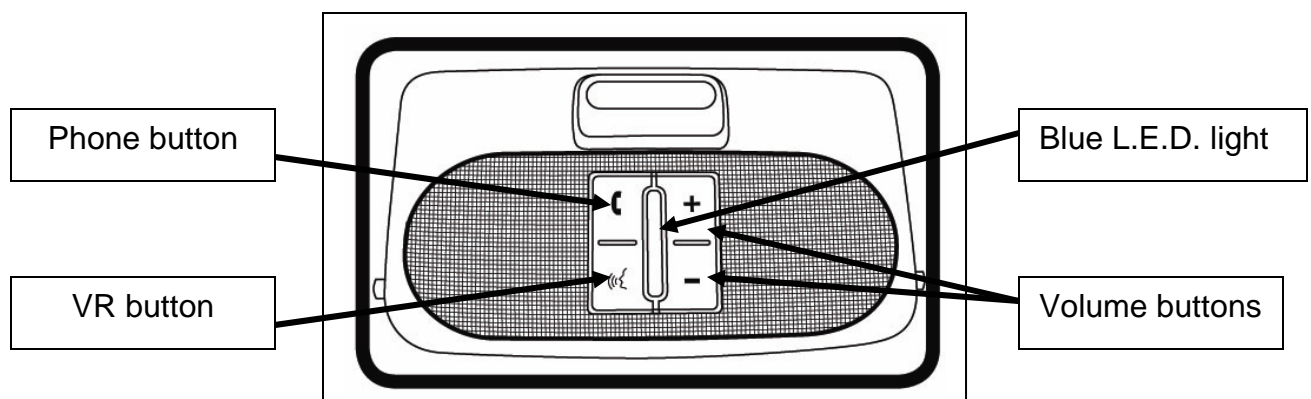

HEADLINER INSTALLATION

- Refer to the questions on page 5 & 6 of this document before starting the installation process.
- ALWAYS disconnect the NEGATIVE (-) terminal at the battery before starting ANY electrical installation on ANY vehicle.
- It is recommended that the UIB assembly be installed in an overhead console if possible. Only use a headliner installation if 1) there is no overhead console installation possible, 2) it is a molded headliner, and 3) there is adequate space available in the headliner.
- DO NOT CUT THE HEADLINER UNLESS YOU HAVE FIRST CONFIRMED THAT THE UIB ASSEMBLY WILL FIT PROPERLY (as outlined in step 13.0).

13.0 DETERMINING THE BEST LOCATION FOR THE UIB ASSEMBLY

When locating an area in the headliner for the UIB assembly, use the template supplied as a guide. You may need to pull the headliner down slightly from the front and 1) place the UIB assembly and HFM under it in order to determine if they will fit and 2) make certain there are no wires or other obstructions behind the selected area.

PLEASE READ THE FOLLOWING GUIDELINES BEFORE MARKING OR CUTTING THE HEADLINER

- There must be enough space above the headliner for both the UIB assembly and the HFM to be installed properly.
- The location must allow for the headliner to maintain its original contour or position without any noticeable changes after the UIB assembly and HFM are installed.
- The UIB assembly faceplate must lay flat (flush) with the headliner surface once it is installed.
- The location selected must be within the range (length) of the wiring harness requirements.
- The location selected is clear of any existing wiring or other obstructions that could interfere with the installed components.
- The location selected is a desired location for the UIB assembly for both voice recognition and driver accessibility.

If any of these guidelines cannot be met then DO NOT install this product in the headliner. You can either try to locate a more appropriate location or “STOP.”

14.0 LOWERING THE HEADLINER

First, most headliners are easy to damage, expensive to replace, and will show dirt easily. We recommend that you use great care when working with headliners and use clean work gloves before handling them. Follow the manufacturers recommended service procedures for lowering the headliner.

The vehicle's headliner only needs to be lowered slightly at the front in order to install the UIB assembly and the HFM. Once the headliner is lowered, place the UIB assembly and the HFM under the headliner in the exact location and position that they are to be installed. Confirm that the guidelines listed in Section 13.0 can be met before continuing.

If all guidelines can be met, remove the adhesive backing from the template and attach it to the headliner surface in the exact position and location selected for the UIB assembly.

15.0 CUTTING THE HEADLINER

Once the template is in position, check again that there are no wires in the way and prepare to make the first cut using a modeling knife with a "fresh" or new blade. Carefully cut along the inside of the oval line and only cut deep enough to separate the molded headliner fabric material away from the headliner backing. This first cut helps reduce any chances of material or fabric runs with a deeper cut.

Once the headliner fabric material is cut away, cut along the same line, but deeper, to remove the remaining material. Check the firmness of the molded headliner material to confirm that it will support the weight of the UIB assembly unit once it is installed. If the headliner material is thin, it may be necessary to install a reinforced backing plate above the headliner to hold the UIB assembly unit in place.

TO COMPLETE THE INSTALLATION PROCESS - Refer to page 8 of this manual and follow installation steps 5.0 – 10.0 and 12.0

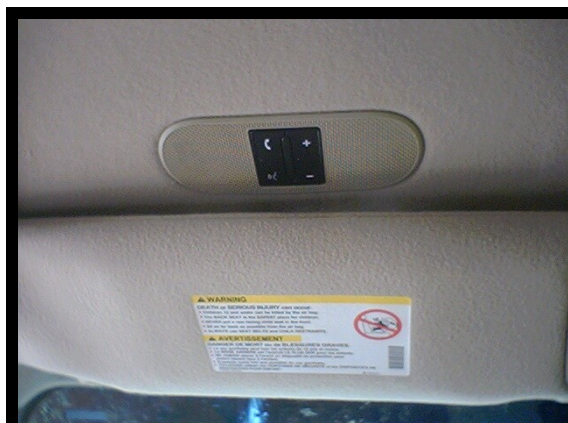

Pictured is a UIB assembly installed in a headliner directly over the driver seat and in front of the sun visor.

TROUBLESHOOTING & WARRANTY INFORMATION

Troubleshooting and product warranty information can be found in the CUSTOMER'S USER GUIDE. You can also contact AutoIntelligence or an Authorized BlueConnect® installation facility on questions regarding this product's operation and its warranty.

INSTALLATION SUPPORT

IF YOU NEED

- TO LOCATE AN INSTALLER
- INSTALLATION SUPPORT OR SERVICE
- HAVE QUESTIONS REGARDING THE INSTALLATION OR USE OF THIS PRODUCT

WITHIN THE USA

Contact AutoIntelligence
(Toll Free) at 1-800-406-7132 or 1-765-282-3825
www.autointelligence.com

WITHIN CANADA

Contact NAC
(Toll Free) at 1-866-343-3025
www.autointelligence.com

OUTSIDE OF THE USA & CANADA

Contact AutoIntelligence
Call 01-765-282-3825
www.autointelligence.com

NOTES



1300 West 23rd Street
Muncie, IN, USA 47302

www.autointelligence.com

BlueConnect® is a registered trademark of Johnson controls.